

Model: **FP 800**
RCI Technologies
Universal Fuel Purifier

Nominal Flow: 15 gal/min (56.8 lts/min)
 In & Out Couplings:..... 1" NPT
 Top Port: 1/2" NPT
 Sensor Port *:..... 1/8" NPT
 Drain Valve:..... Comm/Brass 1/2" Valve
 Height:..... 16.0" Strap mount
 Width: 4.5" (114.3 mm)
 Gross Weight: 11 lbs.
 *Water Sensor and Heater are optional items.



APPLICATIONS

Stationary Diesel
 Pumps and
 Equipment

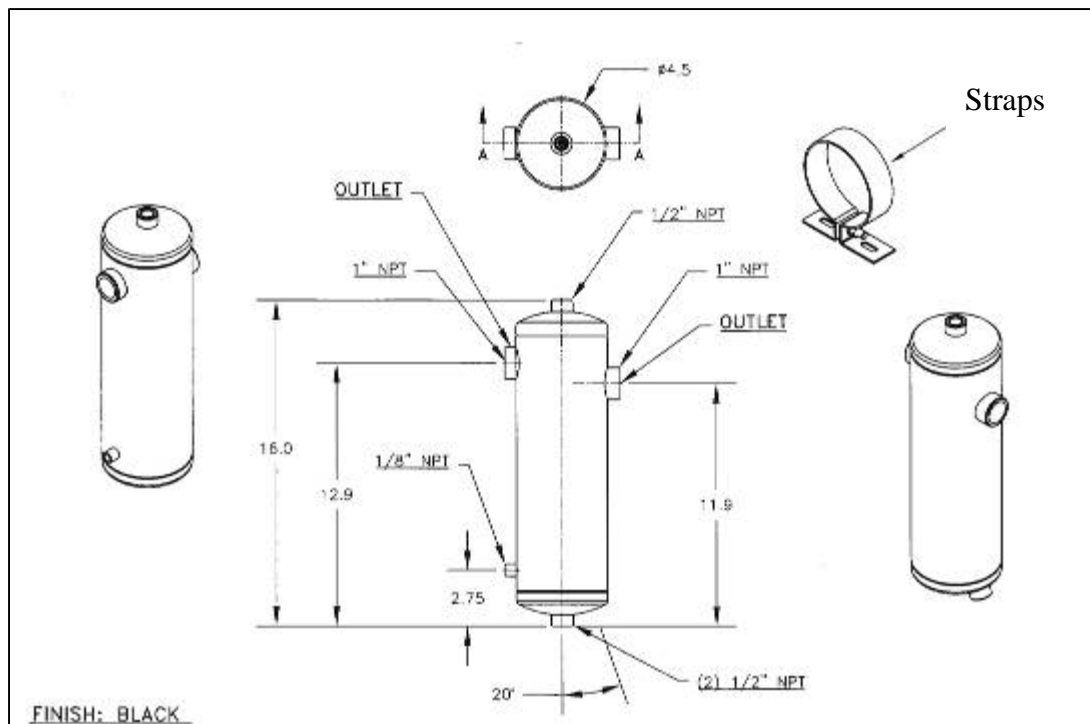
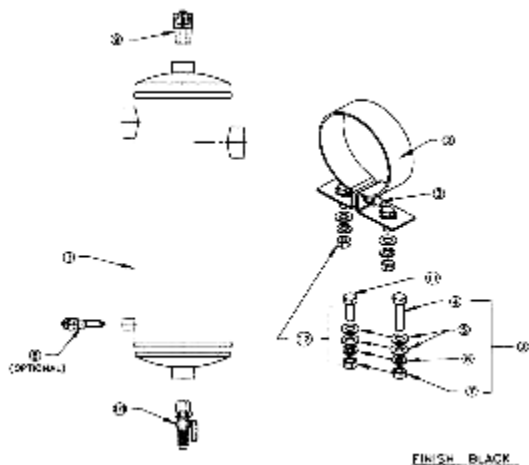

ITEM	PARTS NO.	DESCRIPTION	QTY.
1	FP 800	FUEL PURIFIER	1
2	RC-002	BRACKET	2
3	RC-150	BOLT ASSY.	2
4	RC-151	BOLT 3/8 - 16 x 1.5" L.	2
5	RC-014	FLAT WASHER (SAE)	12
6	RC-015	LOCK WASHER	6
7	RC-107	NUT 3/8 -16	6
8	RC-SEN-K	RCI WATER SEN. KIT (OPTIONAL)	1
9	RC-APV	AIR PURGE VALVE	1
10	RC-DVC	DRAIN VALVE COCK	1
11	RC-161	BOLT 3/8 - 16 x 1.0" L.	4
12	RC-149	BOLT ASSY.	4

				NAME				DR	DATE		
				FUEL/WATER SEPARATOR				RLT	20 MAY 04		
				RCI				DC	SCALE		
								KJM	1:1		
								MATERIAL REF:			
				8758				RELEASED	05/20/04		
				RCI TECHNOLOGIES				SIZE	PART NO.		
				SAY DONAS, CALIFORNIA, U.S.A.				A	FP800		
TRANS. NO.	CHK LET	WAS	DATE	BY	APP	TRANS. NO.	CHK LET	WAS	DATE	BY	APP