

Filter Service Indicators Maximize Filter Life

Typical mounting options: on the air cleaner outlet tube, on the intake duct, or remote

Replacing filters based on restriction readings can reduce your maintenance costs significantly. Visual inspection of air filters is not adequate and should not dictate service life. Filters that appear very dirty may still contain a great amount of service life.

Over-servicing and excessive handling of the filter can result in serious consequences: filter damage, improper installation, intake contamination from ambient dust, and/or increased service cost, time and material. In contrast, filter service based on restriction readings can enable you to obtain the longest life possible from the filter, and the best engine protection.

Restriction Readings, Where & When

Restriction readings are normally taken at the air cleaner on the clean side of the air filter. If the air cleaner does not have a restriction tap, readings can be taken anywhere in the system between the air cleaner and the engine. To measure restriction of a naturally aspirated diesel engine, the reading is taken at full-governed RPM with no load.



Filter service indicators are very effective when mounted on the outlet tube of the air cleaner, as is The Informer™ above. This gives the operator constant & accurate visibility of filter life.

Two methods are used to measure the restriction of turbo-charged engines. The first method is to take the reading with the truck on a dynamometer under full load. This result is actual restriction. A locking step gauge is the other method. This popular method will give actual, on-the-road peak readings.

Choose Restriction Measurement Tools that Best Fit Your Applications

Donaldson offers a variety of restriction measuring devices that help you get maximum filter utilization. All measure restriction in inches of water vacuum. All are resistant to vibration, breakage, weather, corrosion, dust and dirt to assure reliable filter restriction readings.



Continuous Reading devices show how much life is left in the filter:

- The Informer™
- Service Gauge for Instrument Panel

Go/No-Go restriction readings on heavy-duty vehicles:

- ServiSignal™
- Visual Restriction Indicator
- Electrical Indicator
- SafetySignal™ for safety filters

In-Field restriction readings on light and medium-duty vehicles:

- In-Field Service Gauge Kit

Maximum Engine Manufacturers Recommended Restriction Limits

Maximum allowable restriction limits are set by the engine manufacturers. If your maximum limit is unknown, contact your engine manufacturer for the maximum limits. Maximum levels are measured at high idle with no load for naturally aspirated and super-charged diesel engines. Turbo-charged diesel, gasoline and carbureted engines are measured at full load with a wide open throttle.

Examples shown in Inches of Water (H₂O) and kiloPascals

Engine Maker	Diesel, Naturally Aspirated	Diesel, Turbo Charged	Compressed Natural Gas
Detroit Diesel	25" / 6.2 kPa	20" / 5 kPa	20" / 5 kPa
Cummins	20" / 5 kPa	25" / 6.2 kPa	15" / 3.7 kPa
Caterpillar	30" / 7.5 kPa	30" / 7.5 kPa	15" / 3.7 kPa
Mack		E7: 20" / 5 kPa E9: 25" / 6.2 kPa	
Navistar		30" / 7.5 kPa	
Volvo		30" / 7.5 kPa	

NOTE: These figures are general guidelines. Restriction limits on specific engine models may vary. Consult your engine manufacturer for definite figures.

Hand tighten filter service indicators (30-40 lbs./inch maximum).

The Informer™ for Graduated, Continuous Readings



The Informer, when mounted on the air cleaner or the dashboard, provides a continuous reading whether the engine is running or is shut down. Reset button is on top. Kit includes full installation instructions and

a P100089 safety filter fitting. For remote mounting, order a P105168 flange and a P105622 90° elbow.

The Informer™

Restriction Limit	Gauge Only	Kit (gauge & fitting)
20" H ₂ O/5 kPa	X002278	X002103
25" H ₂ O/6.2 kPa	X002277	X002102
30" H ₂ O/7.5 kPa	X002275	X002101

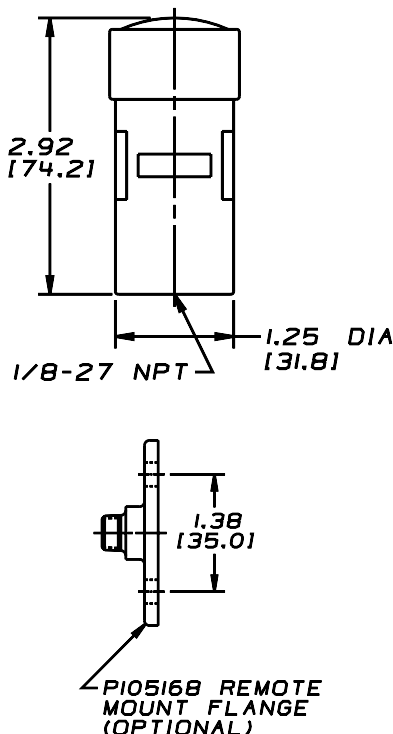

The Mini-Informer™ for Light & Medium Trucks

The Mini-Informer restriction gauge is designed to mount in the plastic air cleaners of passenger cars, light trucks, and sport utility vehicles. It's an accurate, durable, easy-to-read "go/no go" style indicator, smaller than the original Informer.



Through the clear window, a green flag shows when air filter restriction is below the service point. When the restriction reaches its limits, an orange flag imprinted with "change filter" pops up.

The Mini-Informer mounts in the air cleaner ducting in a rubber grommet.

The Mini-Informer™

Restriction Limit	Gauge & Grommet	Gauge Only
25" H ₂ O/6.2 kPa	X007276	X007335

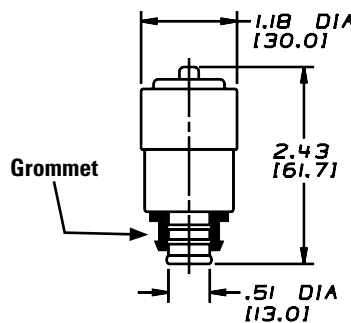

ServiSignal™ Mini Indicator

Small enough to fit just about anywhere (only 1.66" high), the Donaldson ServiSignal shows a highly visible, bright red flag in the full-view window when restriction limit is reached. Resets manually via top button after air cleaner service.



Kit includes 1/8" NPT threaded brass fitting for mounting on the air cleaner. For remote mount, also order P105168 flange. Hoses not included.

The ServiSignal™ Mini Indicator

Restriction Limit	Gauge Only	Kit (gauge & fitting)
15" H ₂ O/ 3.7 kPa	X002250	X002350
20" H ₂ O/ 5 kPa	X002251	X002351
25" H ₂ O/ 6.2 kPa	X002252	X002352
30" H ₂ O/ 7.5 kPa	X002254	X002354

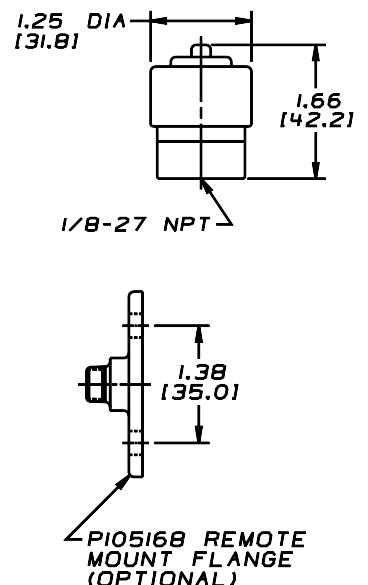

INTAKE ACCESSORIES

Hand tighten filter service indicators (30-40 lbs./inch maximum).

Visual Restriction Indicator

The Donaldson standard restriction indicator can be mounted directly on the air cleaner or remotely on the instrument panel or firewall. When restriction limit is reached and filter service is needed, easily-visible, bright red shows through the full-view window. After the filter is serviced, reset via rubber button on top. For remote mount, also order a flange, P105168. Hoses not included.



Visual Restriction Indicator

Restriction Limit	Gauge Only	Kit (gauge & fitting)
15" H ₂ O/ 3.7 kPa	X002215	X002315
20" H ₂ O/ 5 kPa	X002220	X002320
25" H ₂ O/ 6.2 kPa	X002225	X002325
30" H ₂ O/ 7.5 kPa	X002230	X002330

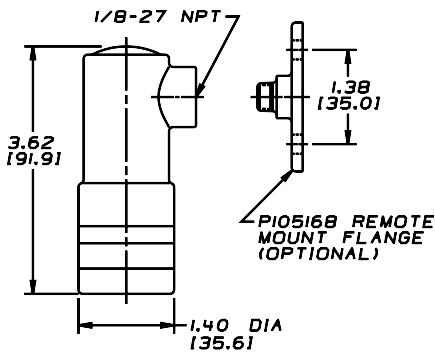

Electrical Indicator Connects to Light, Buzzer, or Computer

Our electrical indicator is designed for a variety of on- and off-highway applications within operating temperatures of -40°F to +212°F (-40°C to +100°C). When restriction level reaches the maximum recommended limit, an electrical signal activates a light, a buzzer, or a computer, as you choose. The indicator automatically resets itself after the filter is serviced.



- 12-24 Volts
- Maximum load: 6 watts (light or buzzer)
- Contacts have no polarity
- Switch contacts are normally in the open position
- Quick connectors and light, buzzer, or computer must be purchased separately

Electrical Indicator

Restriction Limit	Electrical Indicator
15" H ₂ O/ 3.7 kPa	X770037
20" H ₂ O/ 5.0 kPa	X770050
25" H ₂ O/ 6.2 kPa	X770062
30" H ₂ O/ 7.5 kPa	X770075

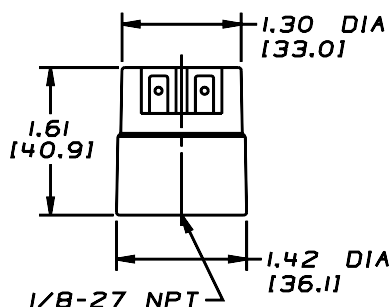

SafetySignal™ Wing Nut Indicator for Safety Filter

The Donaldson SafetySignal service indicator replaces the wing nut on the metal end cap safety filters and constantly monitors air restriction. When service is required, it locks red. The SafetySignal requires no special fittings or adapters. Donaldson safety filters are designed to last through multiple primary filter change outs. The SafetySignal helps save time and money by preventing over-servicing.



SafetySignal™ Order Numbers

PART NO.: X004814

For Air Cleaners: FTG 13" & 15", FHG12" & 14", FVG16"
Fits Bolt: 7/16" - 20 UNF
Washer included: P111551

PART NO.: X004815

For Air Cleaners: FTG11
Fits Bolt: 7/16" - 20 UNF
Washer included: P101872

PART NO.: X004816

For Air Cleaners: FVG14-16", STG12-16"
& All SRG models
Fits Bolt: 1/2" - 13 UNC
Washer included: P105740

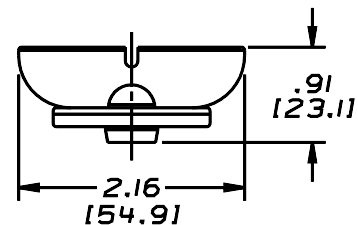

INTAKE ACCESSORIES

Service Gauge for Instrument Panel

Continuously reads restriction in inches of water vacuum when engine is in operation and installs conveniently on instrument panel or wherever operator can easily see the dial. Mounts into a 2-5/8" diameter hole. Hoses not included.



Gauge Part No. X002730
Restriction Limit: 30" H₂O/ 7.5 kPa
Kit includes nuts, mounting bracket and installation instructions.

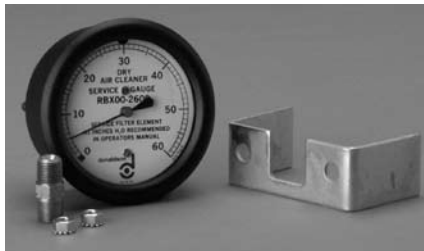

Gauge Part No. X002700
Restriction Limit: 60" H₂O/ 15 kPa
Kit includes restriction tap fitting (P112257), nuts, mounting bracket and installation instructions.

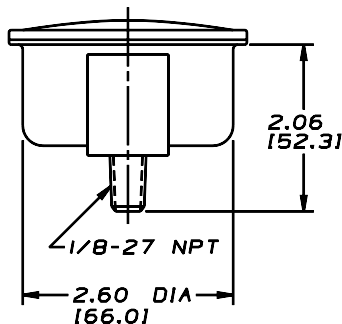

In-Field Service Gauge Kit

Equipped with three feet of vacuum hose to test the air cleaner restriction in the field. Sturdy, compact plastic case, measuring only 6" x 7.25" x 2.25", stores easily. Gauge reads in inches of water vacuum, up to 25" H₂O/ 6.2 kPa. Full instructions included.

Part No. X003903



Water Manometer Kit

Part No. P134534



The Donaldson water manometer kit includes the manometer (flexible tubing), green dye, and full instructions. Manometer, range 18-0-18 in., 17-1/2 oz. mercury. Magnets conveniently hold top and bottom ends of manometer to side of equipment or vehicle. Special shut-off valve eliminates the need to empty water after use.



Restriction Tap Fittings

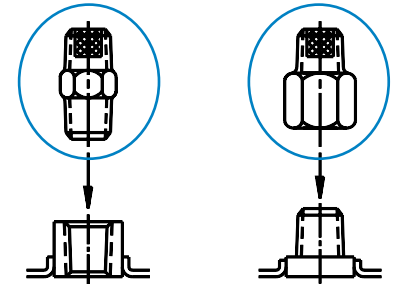

Part No. P100089
• Male threads both ends
• 1/8"-27 thread
• 0.44" (11mm) hex nut
• Internal sintered bronze safety filter

Part No. P122067
• Female threads on one end, male threads on opposite end
• 1/8"-27 thread
• Internal sintered bronze safety filter

Restriction Indicator Fitting

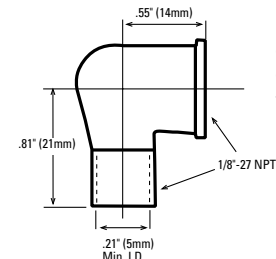

Part No. P105622
• 1/8"-27 threads
• 90° elbow with threaded end

Restriction Tap Sleeve

Install this sleeve in your intake system to convert from scheduled maintenance to more economical restriction maintenance practices.



Restriction Tap Sleeves

Fits Pipe O.D.	Part Number
5" / 127mm	P521639
6" / 152mm	P521641