

Many Sizes Designed To Fit All Donaldson Air Cleaners

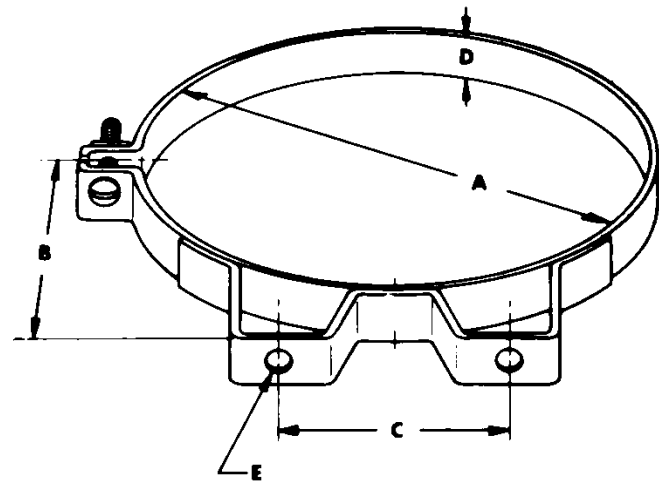

Most of our air cleaners with metal housings require two mounting bands.

- Durable, corrosion resistant, steel construction
- Fully engineered and tested to resist the adverse effects of vibration
- Mounting band feet are designed to ensure maximum torque pressure, continuously
- Gauge of steel increases as diameter of mounting band increases
- Bright stainless models available
- Bolt and nut included with mounting band



Air Cleaner Mounting Bands

A		B		C		D		E		Weight		Max. Bolt Torque		Part Number
inch	mm	inch	mm	inch	mm	inch	mm	inch	mm	lbs	kg	lbs-ft	N•m	
4.00	102	2.56	65	2.50	64	.75	19	.31	8	0.30	0.14	1.50	2.03	P007189
5.25	133	3.19	81	3.25	83	.88	22	.34	9	0.70	0.32	1.50	2.03	P002348
6.00	152	3.56	90	3.25	83	1.00	25	.34	9	0.80	0.36	1.50	2.03	P002351
6.50	165	3.88	99	3.75	95	.88	22	.41	10	0.70	0.32	2.00	2.71	P007191
7.00	178	4.13	105	4.50	114	.88	22	.30	8	0.80	0.36	3.00	4.07	P004906
7.75	197	4.44	113	4.25	108	1.00	25	.34	9	0.90	0.41	3.50	4.75	P003245
8.00	203	4.50	114	4.25	108	1.00	25	.34	9	1.10	0.50	4.00	5.42	P004307
9.00	229	5.13	130	4.5	114	1.25	32	.45	11	1.50	0.68	4.00	5.42	P004073
10.19	259	5.75	146	5.00	127	1.25	32	.45	11	1.50	0.68	4.00	5.42	P004076
11.00	279	6.13	156	5.00	127	1.25	32	.45	11	1.70	0.77	4.00	5.42	P004079
11.81	300	6.88	175	6.00	152	1.50	38	.41	10	2.50	1.13	4.00	5.42	H000349
13.00	330	7.25	184	6.00	152	1.50	38	.41	10	2.80	1.50	4.00	5.42	P013722
		7.25	184	6.00	152	1.50	38	.41	10	2.80	1.50	4.00	5.42	P522439*
14.00	356	8.13	207	8.00	203	1.50	38	.47	12	3.70	1.68	5.00	6.78	H000350
15.00	381	8.00	203	8.00	203	1.50	38	.47	12	4.10	1.86	6.00	8.14	P016845
		8.00	203	8.00	203	1.50	38	.47	12	4.10	1.86	6.00	8.14	P524552*
16.00	406	9.13	232	10.00	254	1.50	38	.47	12	4.75	2.16	5.00	6.78	H000351
18.00	457	9.2	234	15.75	400	1.96	50	.55	14	5.25	2.38	5.00	6.78	H770037
19.29	490	10.97	279	19.29	490	1.96	50	.55	14	6.39	2.9	5.00	6.78	H770068

* Bright Stainless Model