

# Baldwin PF7698

## Provides Convenience, Performance, Value...

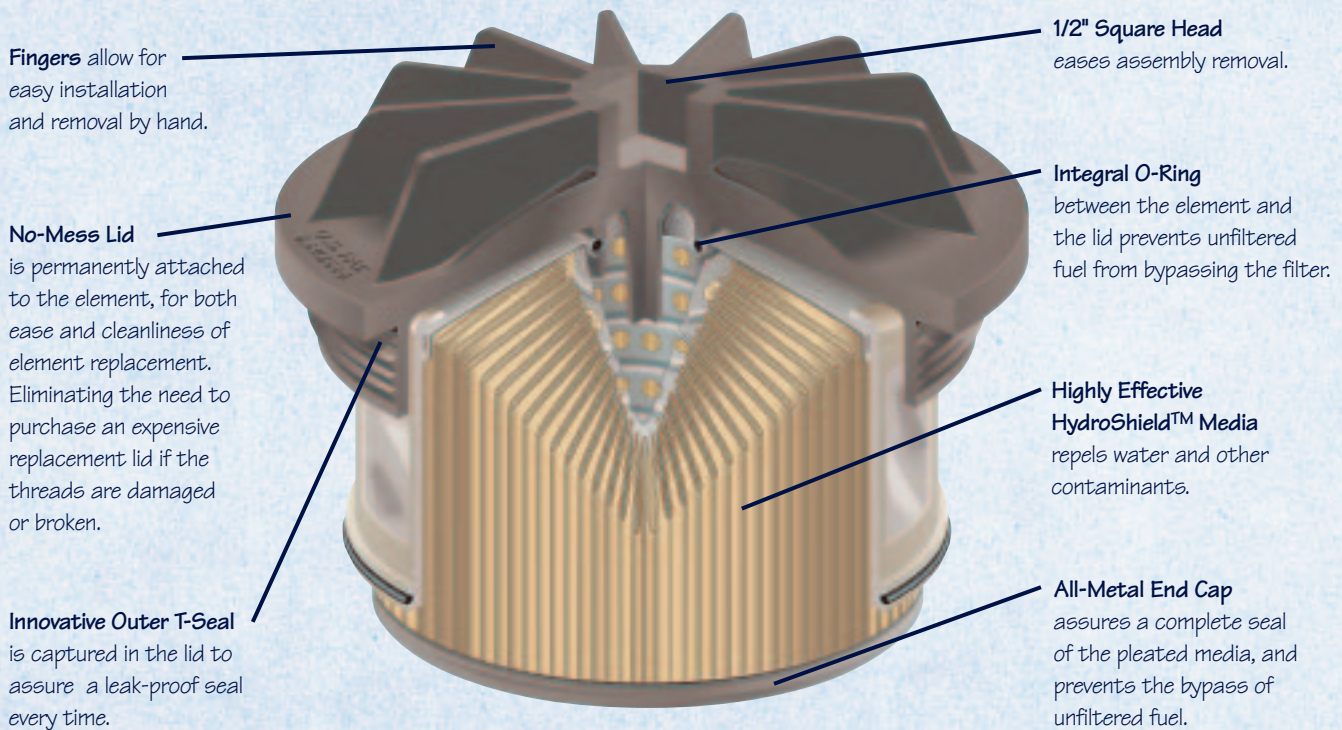

Baldwin Filters offers a complete line of fuel filters.

Baldwin Filters offers an innovation in fuel filter design. The PF7698 incorporates features that make installation and removal of the filter quick and efficient. The PF7698 design prevents your hands from getting covered with diesel fuel while pulling the dirty element out of the housing. For the best performance and protection of your fuel system, be sure to check out the full line of Baldwin fuel filters.

**BALDWIN**  
Heavy-Duty Performance **FILTERS**®

# Baldwin PF7698 Combines Ease of Filter Installation with Superior Fuel Filtration



Baldwin Filters' PF7698 design has made it easier than ever for the user to replace the filter while simultaneously assuring that the housing gasket is positioned to provide a leak-proof seal.

The PF7698 has the housing lid permanently attached to the filter

element. By providing this to the customer pre-assembled, the installer can change the filter without getting diesel fuel on their hands. Another advantage of providing a new lid with each filter is that there is no longer a need to buy an expensive, hard-to-find OEM replacement lid, should the threads become damaged or otherwise broken.

As an added convenience, the Baldwin PF7698 lid incorporates ergonomically-designed raised fingers for easy installation by hand. If more leverage is required for loosening, a 1/2" square head can be used for applying the additional torque.

The user can also be confident that the filter will form a seal with the

housing, because the innovative "T-Seal" attaches to the lid, insuring proper alignment every time. With the Baldwin method, there is no worry of improper orientation of the seal, unlike the loose beveled gasket provided by others.

When it comes to filter performance, you can expect the best the industry has to offer from Baldwin Filters. In controlled, industry-standard laboratory tests, our product meets or exceeds the OEM standards, doubling the dirt-holding capacity while equaling the contaminant removal efficiency. The PF7698 delivers superior filtration performance in a convenient, easy-to-service package.

## Tests Prove Performance Superiority

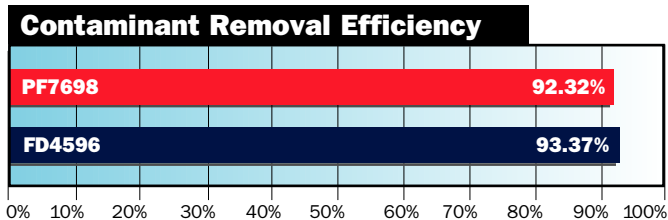
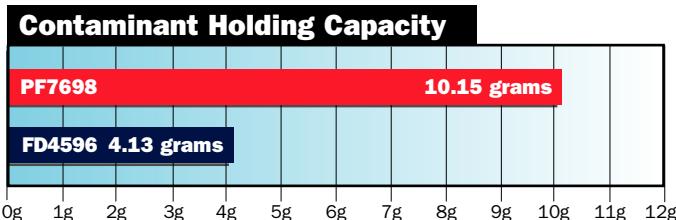

SAE J905 Test: Flow Rate 120 gph, PTI Fine Test Dust, 100°F, Termination at 5 psid

**Africa**  
Baldwin Filters South Africa  
Ph: 27-21-534-0029  
Fax: 27-21-534-3730  
E-mail: africa@baldwinfilter.com

**Mexico**  
Filtros Baldwin de Mexico, S.A. de C.V.  
Ph: 5255-5445-0660  
Fax: 5255-5446-0677  
E-mail: mexico@baldwinfilter.com

**Australia & New Zealand**  
Baldwin Filters Aust., Pty. Ltd.  
Ph: 61-3-9353-7300  
Fax: 61-3-9353-7301  
E-mail: australia-newzealand@baldwinfilter.com

**Middle East**  
Baldwin Filters  
Ph: (308) 237-9782  
Fax: (308) 237-9769  
E-mail: middleeast@baldwinfilter.com

**Central & South America**  
Baldwin Filters  
Ph: (786) 425-1896  
Fax: (786) 425-9138  
E-mail: latinamerica@baldwinfilter.com

**Russia**  
Baldwin Filters  
Ph: (308) 237-9749  
Fax: (308) 237-9769  
E-mail: russia@baldwinfilter.com

**China**  
Baldwin Filters  
Ph: 852 2814 7722  
Fax: 852 2814 7744  
E-mail: china@baldwinfilter.com

**Southeast Asia & Pacific Rim**  
Baldwin Filters  
Ph: 65-6382-6619  
Fax: 65-6382-6182  
E-mail: southeastasia@baldwinfilter.com

**Europe**  
Baldwin Filters N.V.  
Ph: 32 3 328 18 88  
Fax: 32 3 328 18 99  
E-mail: europe@baldwinfilter.com

**UK & Ireland**  
Baldwin Filters Ltd.  
Ph: 44-1702-291668  
Fax: 44-1702-290846  
E-mail: uk-ireland@baldwinfilter.com

ISO 9000  
ISO 9001



QUALITY SYSTEM  
CERTIFIED

**BALDWIN FILTERS®** **BALDWIN**

a CLARCOR company

4400 East Highway 30 • P.O. Box 6010  
Kearney, Nebraska 68848-6010  
Phone: (308) 234-1951 • Toll Free: (800) 822-5394  
Fax: (800) 828-4453 • Int'l Fax: (308) 237-9769  
Internet: www.baldwinfilter.com